

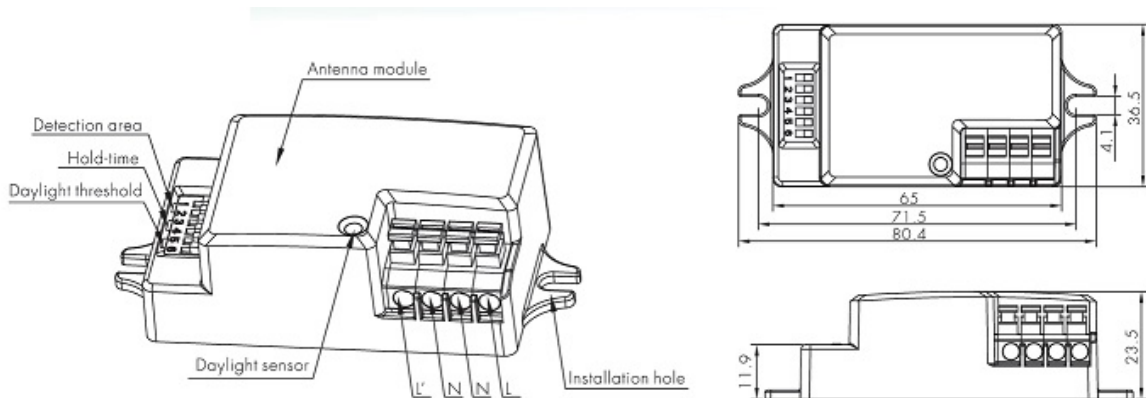

## CLA MICROWAVE SENSOR - SENS006

### FEATURES

- Input voltage: 240V AC 50-60Hz
- Load: 400W (Capacitive Load) 800W (Resistive Load)
- 4 Different hold time modes
- Good detection range
- Suitable for Resistive and Capacitive loads
- Easy set-up switch
- Instructions incl. in box
- IP20 for indoor use
- 3 year replacement warranty
- For use inline before control gear



### SPECIFICATIONS

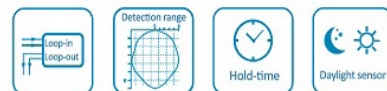

CODE	DESCRIPTION	DETECTION RANGE	DETECTION ANGLE	DETECTION AREA	HOLD TIME	STANDBY POWER	MICROWAVE FREQUENCY	MOUNTING HEIGHT	AMBIENT TEMPERATURE
SENS006	Microwave Sensor	( $\phi$ x H) 10mx6m	30° ~ 150°	10%/50% 75%/100%	5sec/90sec 5min/15min	< 0.5W	5.8GHz +- 75MHz	6m	-20°C ~ 60°C

UPDATED ON 08/05/2017